

## Assembly Instructions

Tools Required: Adjustable wrench (or 1/2, 11/16, box wrench), hammer.

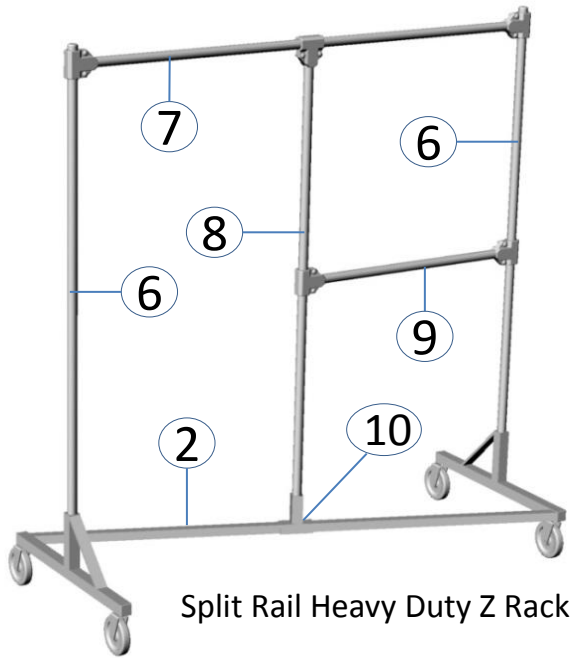

Split Rail Heavy Duty Z Rack

### PARTS LIST

1. Stem Swivel Caster (x4)
2. Garment Rack Frame (x1)
3. Square End Cap (x4)
4. 7/16" Lock washer (x4)
5. 7/16" Hex Nut (x4)
6. Upright Bar (x2) 72"
7. Top Bar (x1) 60"
8. Middle upright bar (x1) 69"
9. Middle Crossbar (x1) 29 1/4"
10. Flange Tee (x1)
11. 5/16" Carriage Bolt (x10)
12. 1"x1" Brace Clamp (x5/ 10 pcs.)
13. 5/16" Kep Nut (x10)
14. Round End Cap (x2)

### Assembly Instructions – Frame

1. Insert Casters (1) into frame (2) and Tighten 7/16" lock washer (4) and 7/16" hex nut (5).
2. Insert Flange Tee (10) on top of frame (2) then insert middle upright (8) and Upright Bars (6).
3. Insert Square end caps (3) into Frame.

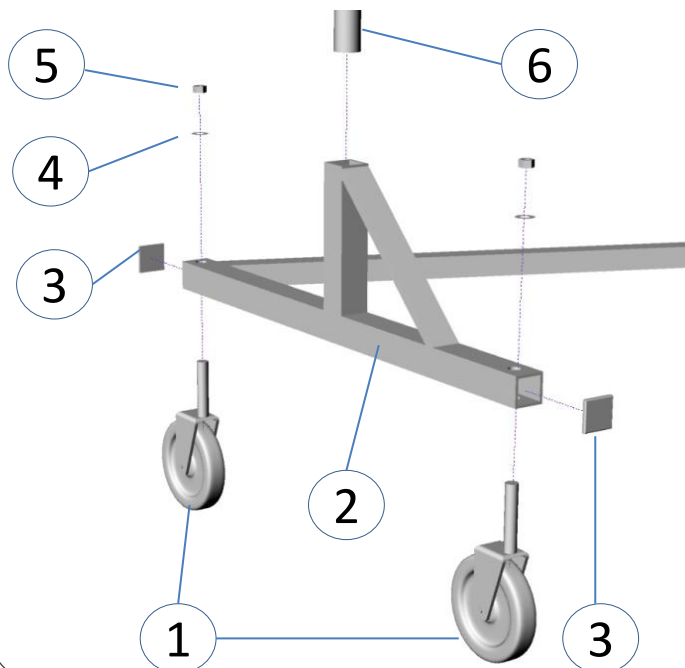

### Assembly Instructions – Brackets

1. Attach top rail bar (7) and Upright Bars (6)(8) using brace clamps (9), 5/16" carriage bolts (11) and 5/16" Kep nuts (13).
2. Repeat sequence for Middle Crossbar (9) by securing Clamp assemblies (9,11,13) to Upright Bars (6,8).
3. Insert round end caps (14) into upright bars (6).

