

Assembly Instructions

Tools Required: Adjustable wrench (or 1/2, 11/16, box wrench), hammer.

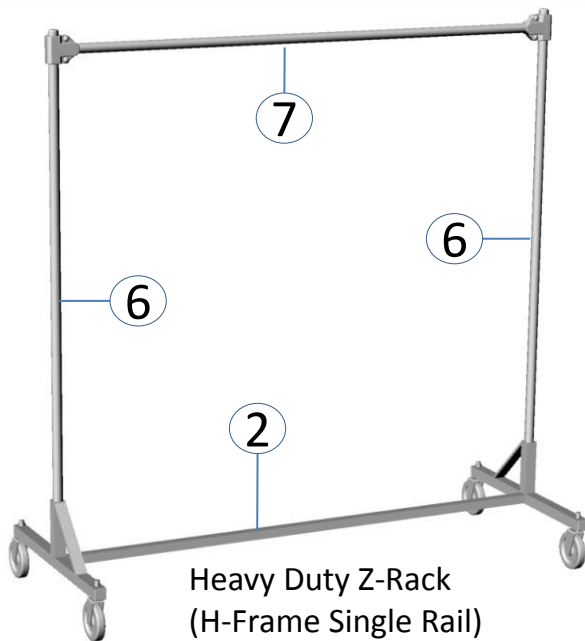

PARTS LIST

1. Stem Swivel Caster (x4)
2. Garment Rack Frame (x1)
3. Square End Cap (x4)
4. 7/16" Lock washer (x4)
5. 7/16" Hex Nut (x4)
6. Upright Bar (x2)
7. Top Rail Bar (x1)
8. 5/16" Carriage Bolt (x4)
9. 1"x1" Brace Clamp (x2 / 4 pieces)
10. 5/16" Kep Nut (x4)
11. Round End Cap (x2)

Assembly Instructions – Bottom

1. Insert Casters (1) into frame (2)
2. Tighten 7/16" lock washer (4) and 7/16" hex nut (5).
3. Insert Square end caps (3) into Frame.

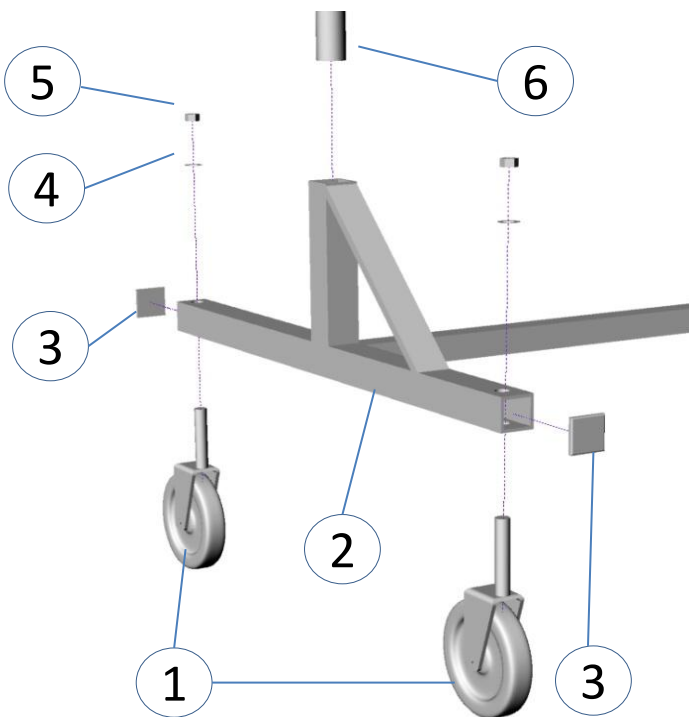

Assembly Instructions – Brackets

1. Attach top rail bar (7) and Upright Bar (6) using brace clamps (9), 5/16" carriage bolts (8) and 5/16" keps nuts (10).
2. Insert round end caps (11) into upright bar (6).
3. Assemble Top and Bottom assemblies to complete the Z-Rack.

