

Cover Support Instructions



www.zracks.com

Cover Supports

PARTS LIST

1. 22.5 Support Bar (x2)
2. 1"x1" Brace Clamps (x2 / 4 pieces)
3. 5/16" Carriage Bolt (x4)
4. 5/16" Kep Nut (x4)
5. Rounded End Caps (x4)

ASSEMBLY INSTRUCTIONS

1. Attach one cover support bar to the top of one upright using brace clamp (2), 5/16" Carriage bolts (3), and 5/16" kep nuts (4). Round end caps (5) will need to be hammered on. Repeat process on other upright.

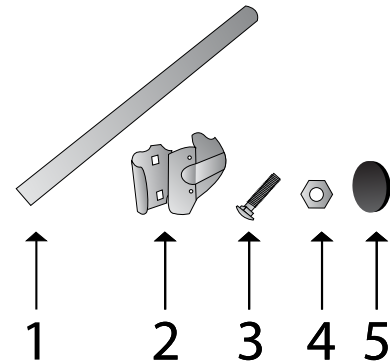

Tools Required: Adjustable wrench (or 1/2, 11/16 box wrench), hammer.